

ITEM	DESCRIPTION
①	3" NORMAL VENT FITTING
②	2"-8 OZ. EMERGENCY VENT -- SHIP LOOSE
③	EMERGENCY VENT OVERFLOW CHUTE
④	VENT DEFLECTOR ASSEMBLY
⑤	2" FITTING
⑥	2" FILL FITTING
⑦	1" OVERFLOW PIPE
⑧	1" PIPE UNION
⑨	_____
⑩	FILL CONTAINMENT CHAMBER
⑪	_____
⑫	_____
⑬	_____
⑭	_____
⑮	_____
⑯	1 1/2" L (2)

AUTHORIZATION

COMPANY NAME _____

APPROVED BY (PLEASE PRINT) _____

APPROVAL SIGNATURE _____

DATE _____ CONTRACT NO. _____

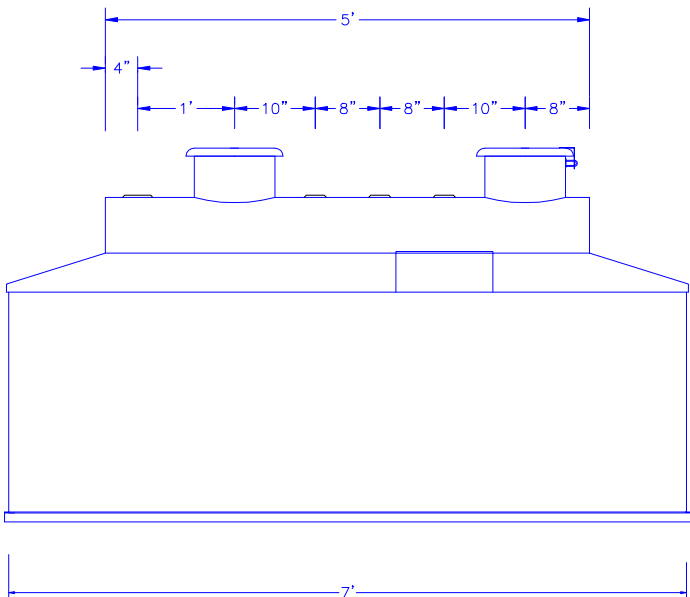

SECTION A-A

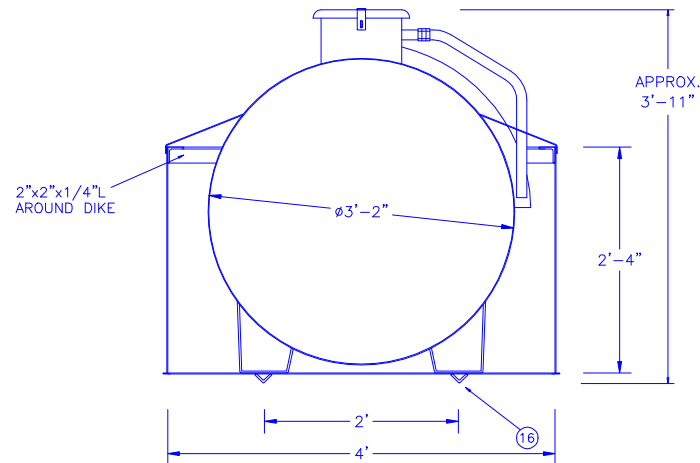

- NOTES
1. PRIMARY TANK:
SHELL - 12 GA. HEAD - 12 GA.
CONTAINMENT: 12 GA.
 2. MATERIAL - MILD CARBON STEEL
 3. TEST AT 5-7 PSIG.
 4. ENTIRE UNIT UL LISTED.
 5. EXTERIOR FINISH -
 6. ALL DIMENSIONS APPROXIMATE.

All rights reserved. This drawing or any part thereof must not be reproduced in any form without the written permission of Areo-Power Unitized Fueler, Inc.

AREO-POWER®

TITLE	300 GAL. AREO-POWER TANK MODEL 3048	REV #	REV DATE
U.S. PATENT #	4895272	CANADIAN PATENT APPLIED FOR	
SCALE	DATE	DRAWN BY	DWG. NO.
3/4"=1'	8/1/92	JF	APP530