

**GENERAL SPECIFICATIONS**

PAGE 1 OF 2 PAGES: SEE PAGE 2 FOR IMPORTANT GENERAL SPECIFICATIONS

NO. REQ'D: (1)  
 CAPACITY: 5000 GALLON OIL WATER SEPARATOR  
 TYPE: AREO-POWER , DOUBLE WALL TYPE 1 360  
 DESIGN:  10 P.P.M.  
 15 P.P.M.  
 MATERIAL: MILD CARBON STEEL  
 ESTIMATED WEIGHT: 8082 lbs.  
 FLOW RATE: 500 GPM  
 GAUGE: INNER: OUTER:  
 SHELL- 7GA. 10GA.  
 HEADS- 7GA 7GA  
 SURFACE PREP:  
 SSPC NO.6 BLAST ALL EXTERIOR SURFACES  
 SSPC NO.10 BLAST ALL INTERIOR SURFACES  
 COATING: MATERIAL THICKNESS  
 EXTERIOR-  S.T.I.P. 3 - CORROCOTE PLUS (15 MILS)  
 ACT 100 U - FIBERTHANE (70 MILS)  
 INTERIOR- CORROCOTE P.W. (15 MILS)

**NOTE:**

- INLETS, OUTLETS , & MANWAYS MUST BE VENTED. FAILURE TO VENT OUTLET CAN RESULT IN THE SYPHONING OF THE UNIT
- 15000 VOLT SPARK TEST PROVIDED AT FACTORY FOR FIBERTHANE TANK ONLY

**PROVIDED EQUIPMENT**

- 150# R.F.S.O. FLANGE
- ISOLATION SPOOL PIECE WITH INSULATION KIT & 2" NPT FOR VENT
- VELOCITY HEAD DIFFUSION BAFFLE
- WEAR PLATE
- SEDIMENT CHAMBER
- UNDERFLOW BAFFLE
- REMOVABLE SLUDGE BAFFLE
- STRIKER PLATES
- SYNTHETIC PACK
- OIL/WATER SEPARATOR CHAMBER
- 5"øFTG. W/ 5"øX4"ø NYLON BUSHING FTG. FOR GAUGE WITH PLUG- TYP. BOTH MANWAYS
- OUTLET DOWNCOMER
- 30"ø MANWAY WITH BOLT-ON EXTENSION SHIPPED LOOSE
- 5"øFTG. W/ 5"øX4"ø NYLON BUSHING FTG.FOR OIL PUMP-OUT WITH INTERNAL PIPE INSTALLED & RISER PIPE SHIPPED LOOSE
- 3"øFTG. W/ 3"øX2"ø NYLON BUSHING FTG. FOR LEVEL SENSOR
- LIFTING LUG
- 3"øFTG. W/ 3"øX2"ø NYLON BUSHING FTG. FOR VENT
- COALESCER PACKS WITH PULL ROD FOR 10 PPM MODEL ONLY
- SACRIFICIAL ZINC ANODES FOR S.T.I.P. 3 MODEL ONLY
- P.P.2 MONITORING LUG FOR S.T.I.P. 3 MODEL ONLY
- 3"øFTG. W/ 3"øX2"ø NYLON BUSHING FTG. FOR SENSOR CONDUIT
- 3"øFTG. W/ 3"øX2"ø NYLON BUSHING FTG. FOR LEAK DETECTION

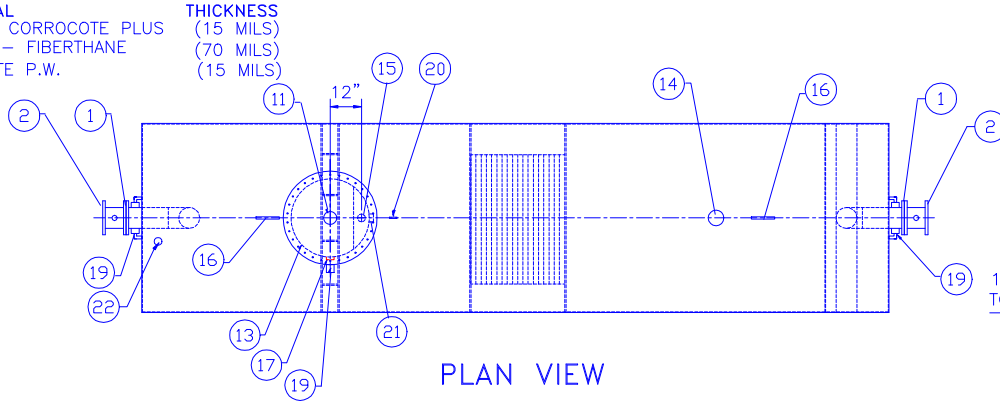

PLAN VIEW

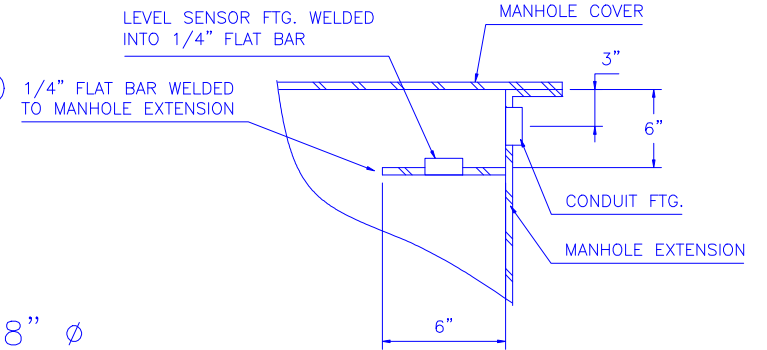

DETAIL-A

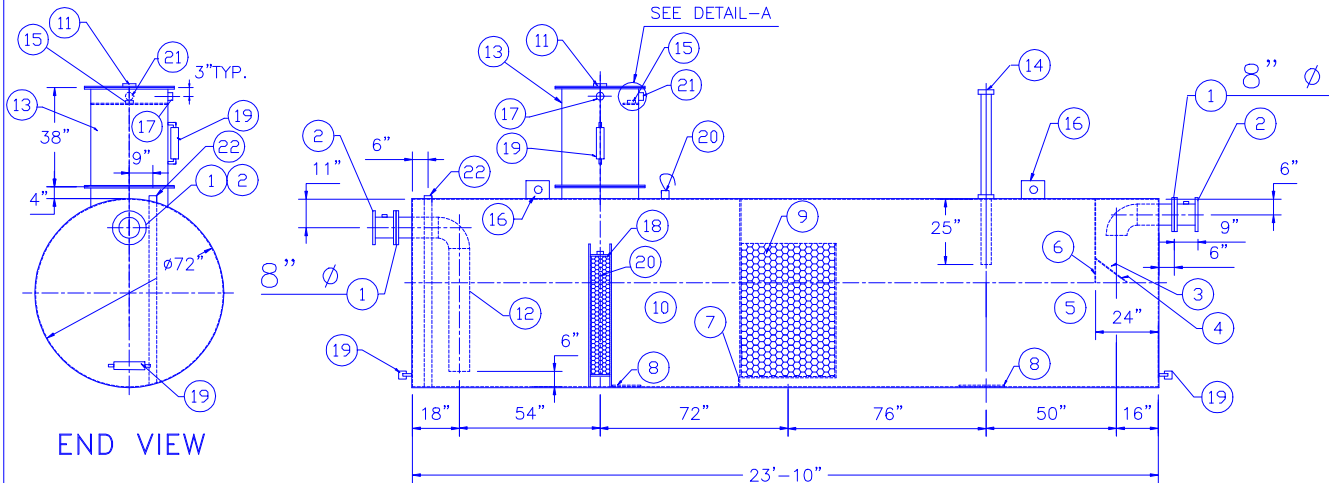

ELEVATION

**AREO-POWER**

UNITIZED FUELER, INC.

OIL WATER SEPARATOR

103 SMITHTOWN BLVD. SMITHTOWN, NY 11787

ALL RIGHTS RESERVED. THIS DRAWING OR ANY PART THEREOF MUST NOT BE REPRODUCED IN ANY FORM WITHOUT WRITTEN PERMISSION OF ANY AREO-POWER UNITIZED FUELER, INC.

CUSTOMER:

QUOTE:

PROJECT:

SCALE: 1/4"=1'-0"	DATE:	DRN. BY:	CHKD BY:	DWG.# AP 5K DW HDS
----------------------	-------	----------	----------	-----------------------